

HD IR Bullet Network Camera Quick Start Guide

Version 1.0.2

Welcome

Thank you for purchasing our Network camera!

This user's manual is designed to be a reference tool for your system.

Please read the following safeguard and warnings carefully before you use this series product!

Please keep this user's manual well for future reference!

Important Safeguards and Warnings

1 . Electrical safety

- All installation and operation here should conform to your local electrical safety codes.
- Please check if the power supply is correct before operating the device.
- The power shall conform to the requirement in the SELV (Safety Extra Low Voltage) and the Limited power source is rated DC 12V or AC 24V in the IEC60950-1. (Power supply requirement is subject to the device label).
- Please install easy-to-use device for power off before installing wiring, which is for emergent power off when necessary.
- Please prevent the line cord from being trampled or pressed, especially the plug, power socket and the junction from the device.
- **Note: Do not connect these two power supplying sources to the device at the same time; it may result in device damage!**
- We assume no liability or responsibility for all the fires or electrical shock caused by improper handling or installation.
- We are not liable for any problems caused by unauthorized modification or attempted repair.

2 . Environment

- Please don't aim the device at strong light (such as lighting, sunlight and so on) to focus; otherwise it may cause overexposure (It is not the device malfunction), which will affect the longevity of CCD or CMOS.
- Please transport, use and store the device within the range of allowed humidity and temperature.
- Please don't keep the device in a place which is wet, dusty, extremely hot, and extremely cold and with strong electromagnetic radiation or unstable lighting.
- Please do not allow water and other liquid falling into the camera in case that the internal components are damaged.
- Please do not allow rain or damp to the indoor device in case fire or lightning may occur.
- Please keep the sound ventilation in case of heat accumulation.
- Please pack the device with standard factory packaging or material with same quality when transporting the device.
- Heavy stress, violent vibration or water splash are not allowed during transportation, storage and installation.

3. Operation and Daily Maintenance

- Please do not touch the heat dissipation component of the device directly in order to avoid scald.
- Please do not dismantle the device; there is no component which can be fixed by users themselves in the machine. It may cause water leakage or bad image for the device due to unprofessional dismantling. Please contact after-sale service to replace desiccant if it becomes green.
- It is recommended to use the device with thunder proof device in order to improve thunder proof effect.
- The grounding holes of the product are recommended to be grounded to further enhance the reliability of the camera.
- Do not touch the CCD (CMOS) optic component directly. You can use the blower to clean the dust or dirt on the lens surface. Please use a dry cloth wetted by alcohol to wipe away the dust gently if it is necessary to clean.
- Always use the dry soft cloth to clean the device. If there is too much dust, please use the water to dilute the mild detergent first and then use it to clean the device. Finally use the dry cloth to clean the device. Don't use volatile solvent like alcohol, benzene, thinner and etc or strong detergent with abrasiveness, otherwise it will damage the surface coating or reduce the working performance of the device.
- Dome cover is an optical device, please don't touch or wipe cover surface directly during installation and use, please refer to the following methods to deal with once dirt is found:
 - Stained with dirt
 - Use oil-free soft brush or hair dries to remove it gently.
 - Stained with grease or fingerprint
 - Use soft cloth to wipe the water drop or oil gently to make it dry, then use oil-free cotton cloth or paper soaked with alcohol or detergent to wipe from the lens center to outward. It is ok to change the cloth and wipe several times if it is not clean enough.

Warning

- Please modify the default password after login in order to avoid being stolen.
- Please use the standard accessories provided by manufacturer and make sure the device is installed and fixed by professional engineers.
- Please prevent the device surface from the radiation of laser beam when using laser beam device.
- Please do not provide two or more power supply modes for the device, otherwise it may cause damage to the device.

Statement

- Please refer to the actual product for more details; the manual is just for reference.
- The manual will be regularly upgraded according to the product update; the upgraded content will be added in the manual without prior announcement.
- Please contact the supplier or customer service if there is any problem occurred when using the device.

- Please contact the customer service for the latest procedure and supplementary documentation.
- There may be deviation between the actual value of some data and the value provided in the manual due to the reasons such as the real environment is not stable and so on. Please refer to the company's final explanation if there is any doubt or dispute.
- The company is not liable for any loss caused by the operation which is not followed by the manual.

FCC Information

1. FCC conditions:

This device complies with part 15 of the FCC Rules. Operation is subject to the following two conditions:

- This device may not cause harmful interference;
- This device must accept any interference received, including interference that may cause undesired operation.

2. FCC compliance:

This equipment has been tested and found to comply with the limits for a digital device, pursuant to part 15 of the FCC Rules. These limits are designed to provide reasonable protection against harmful interference. This equipment generates uses and can radiate radio frequency energy and, if not installed and used in accordance with the instruction manual, may cause harmful interference to radio communication. However, there is no guarantee that interference will not occur in a particular installation. If this equipment does cause harmful interference to radio or television reception, which can be determined by turning the equipment off and on, the user is encouraged to try to correct the interference by one or more of the following measures:

- Reorient or relocate the receiving antenna.
- Increase the separation between the equipment and receiver.
- Connect the equipment into an outlet on a circuit different from that to which the receiver is connected.
- Consult the dealer or an experienced radio/TV technician for help.

Note:

Please refer to the disk for more details, check and download corresponding user's manual and tool. Before installation, please open the package and check all the components are included. Contact your local retailer ASAP if something is broken in your package.

Accessory Name	Amount
Network Camera Unit	1
Quick Start Guide	1
Installation Accessories Bag	1
CD	1

Table of Contents

1	Device Structure	1
1.1	Device External Cable	1
1.2	Framework and Dimension	2
1.3	Alarm Setup.....	3
2	Device Installation	5
3	Network Configuration	9
3.1	Modify IP Address	9
3.2	Login WEB Interface	10

1 Device Structure

1.1 Device External Cable

Note:

- The following figure is for reference only, which is used to know the function of cable port.
- There are differences about cable structure between different models, please refer to the actual product for more details.

You can refer to the following figure for cable information. See Figure 1-1.

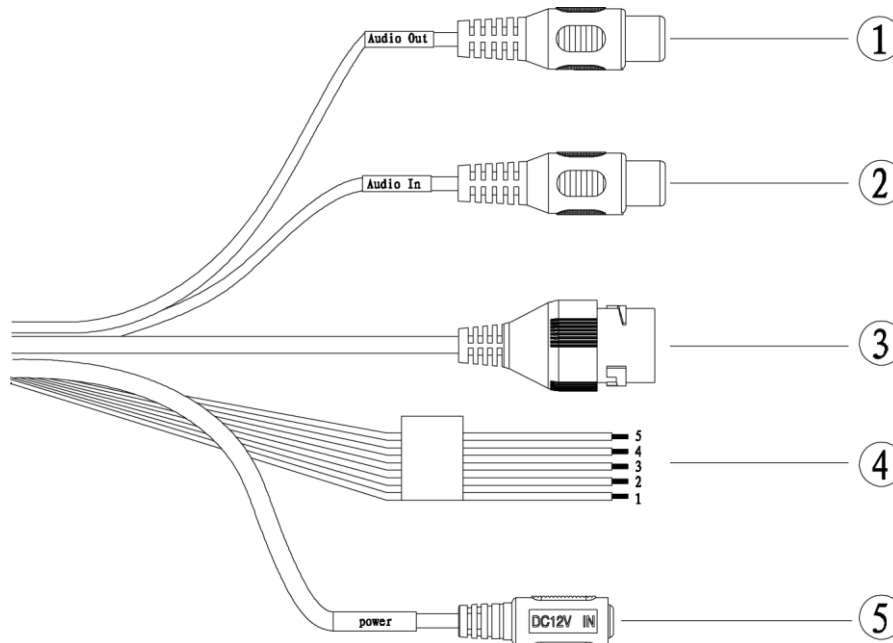

Figure 1-1

Please refer to Table 1-1 for detailed information.

No.	Port Name	Function	Connector	Function Description
1	AUDIO OUT	Audio output port	RCA	Output audio signal to speaker and etc.
2	AUDIO IN	Audio input port	RCA	Input audio signal, receive analog audio signal from pick up and etc.
3	LAN	Network port	Ethernet port	Connect to standard Ethernet cable. Note: Some series don't support PoE.
4	I/O	I/O port	-	Alarm signal input/output.

No.	Port Name	Function	Connector	Function Description
5	Power	Power input port	/	<p>Input DC 12V or AC 24V, please be sure to power the device according to the label instruction when using the device.</p> <p>Note Please use round port to 2PIN converter cable when using AC 24V for power supply.</p> <p>Caution It may cause damage to the device if it fails to power the device according to the device label.</p>

Table 1-1

Please refer to Table 1-2 for detailed pin information.

Port Name	SN	Name	Function Description
I/O Port	1	ALARM_NO	Alarm output port. It is to output the alarm signal to the alarm device. NO: normal open alarm output port. It must be used with ALARM_COM.
	2	ALARM_COM	Alarm output public port.
	3	ALARM_IN1	Alarm input port 1. It is to receive the on-off signal from the external alarm source.
	4	ALARM_IN2	Alarm input port 2. It is to receive the on-off signal from the external alarm source.
	5	GND	Ground port

Table 1-2

1.2 Framework and Dimension

Note

The following figure is for reference only, which is used to know the device dimension.

Please refer to the following figure for dimension information. The unit is mm. See Figure 1-2.

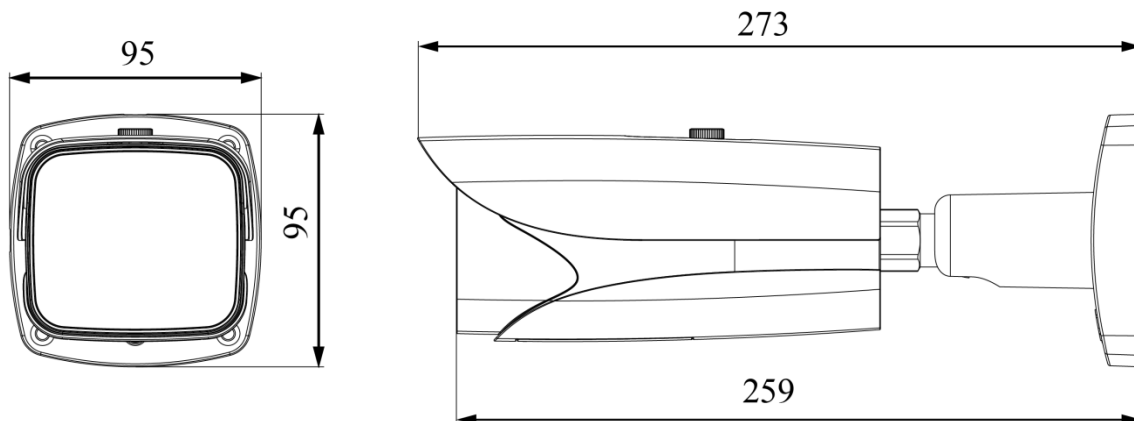

Figure 1-2

1.3 Alarm Setup

Note:

It is only supported by some series products.

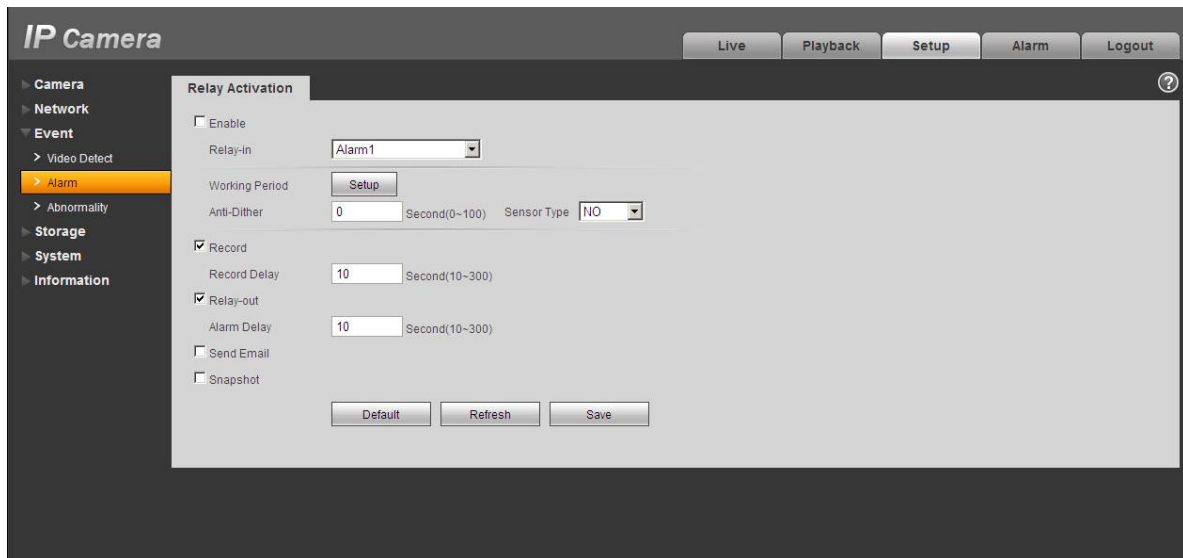

Figure 1-3

Alarm input, output description:

Step 1

Connect alarm input device to the alarm input of I/O port cable.

Step 2

Connect alarm output device to the ALARM_OUT and ALARM_OUT_GND of I/O port cable, Alarm output is the relay switch output; alarm output port can only be connected to NO (normally open) alarm device.

Step 3

Open the WEB, set alarm input and output correspondingly in alarm setup. Alarm input on the WEB is corresponding to that of the device I/O port cable. When there is alarm, alarm input device will generate signal of high and low level. Set corresponding NO and NC inputs.

Step 4

Set alarm output on the WEB, the alarm output is corresponding to the alarm output end of the device, this is the alarm output port of the I/O port cable.

Please refer to the following figure for alarm input and output information. See Figure 1-4.

Alarm input: When the input signal is idle or grounded, the device can collect the different statuses of the alarm input port. The input signal is connected to 3.3V or is idle; the device collects the logic "1". When the input signal is grounded, the device collects the logic "0".

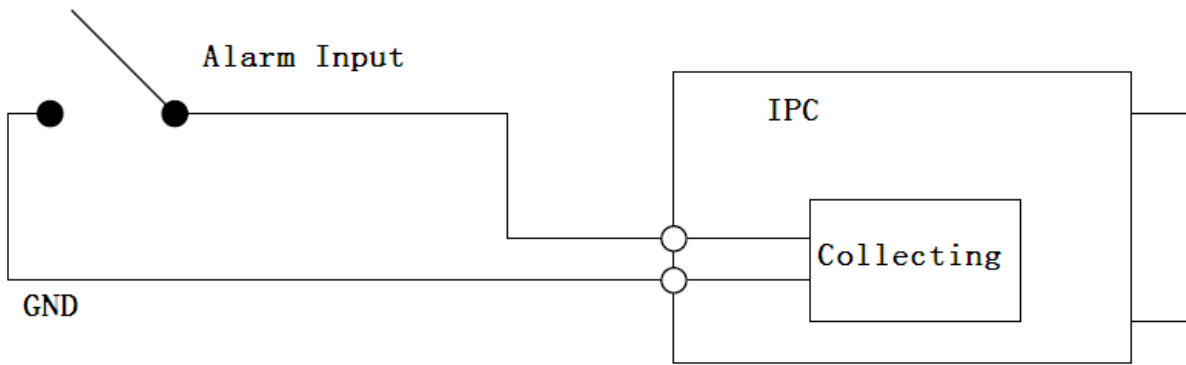

Figure 1-4

Please refer to the following figure for alarm output information. See Figure 1-5 and Figure 1-6.

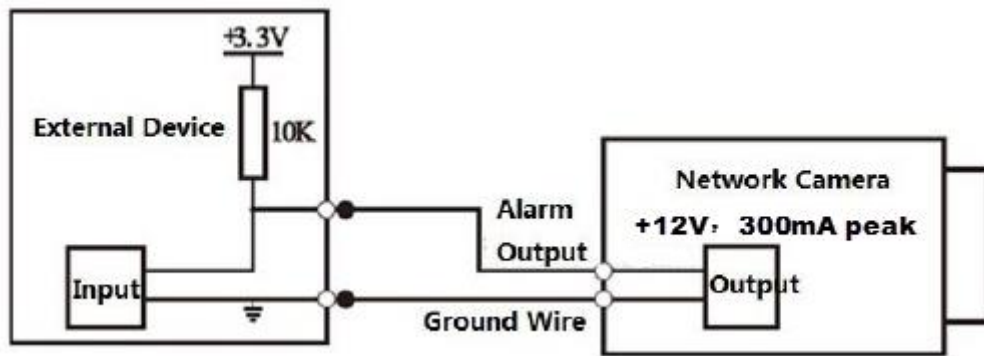

Figure 1-5

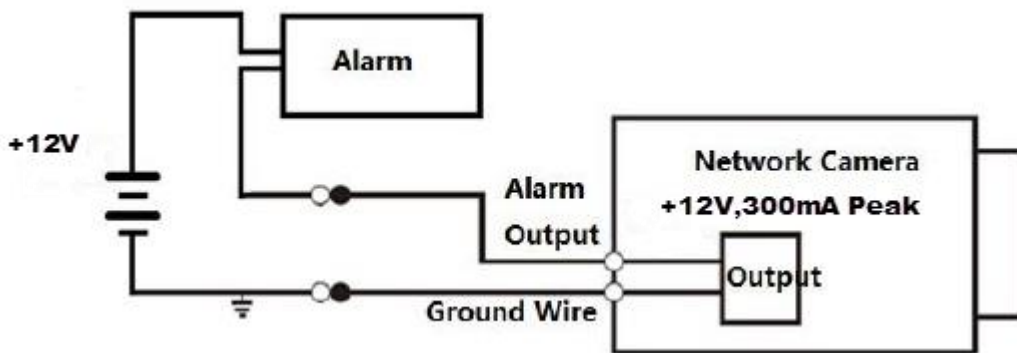

Figure 1-6

Mode A:

Level application. Alarm output high and low level, alarm output is OC; it needs to increase pull-up resistance externally to work normally. Max external pull-up level is 12V, max port current is 300mA (peak). After external pull-up resistance is increased, the default output signal is high level (external pull-up voltage), and it switches to low level when there is alarm output.

Mode B:

Switch application. Alarm output is used to drive external circuit, max voltage is 12V and max current is 300mA (peak), it is recommended to use an audible and visual alarm whose model is H103C.

2 Device Installation

Note

- Please make sure the installation surface can support at least 3X weight of the camera and the bracket.
- Please cut off the device power before installing Micro SD card.

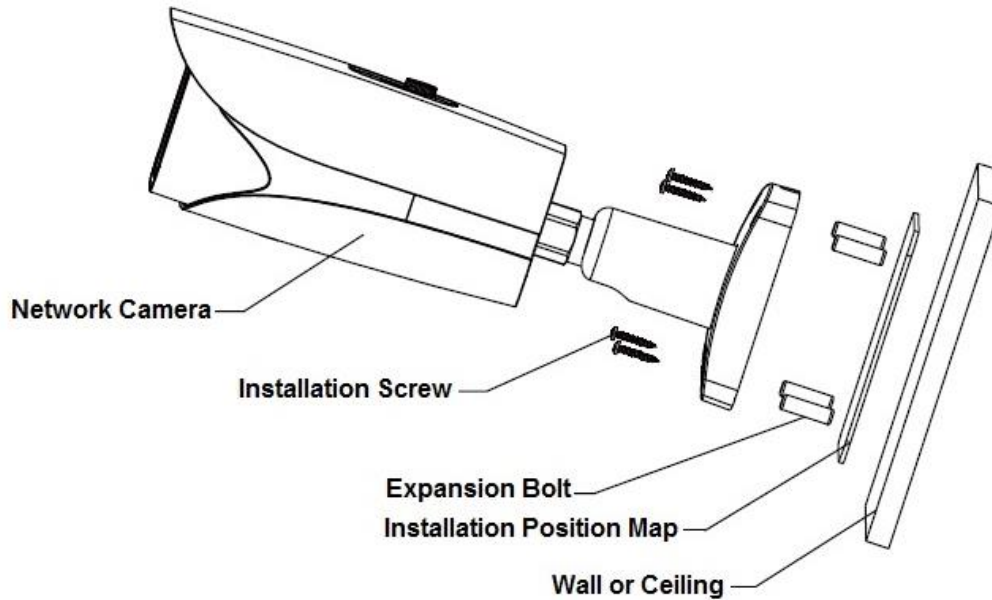

Figure 2-1

Step 1

SD card installation (Optional)

Note

It needs to implement the step when the device is equipped with Micro SD card slot and it needs to use Micro SD card.

1. Loosen the screw on the lower cover.
You can see the Micro SD card, analog output, two direction button and reset button after you open the lower cover.
2. Insert the SD card into the slot which is shown in Figure 2-2, you can press the SD card slightly to insert it because the card slot is elastic.

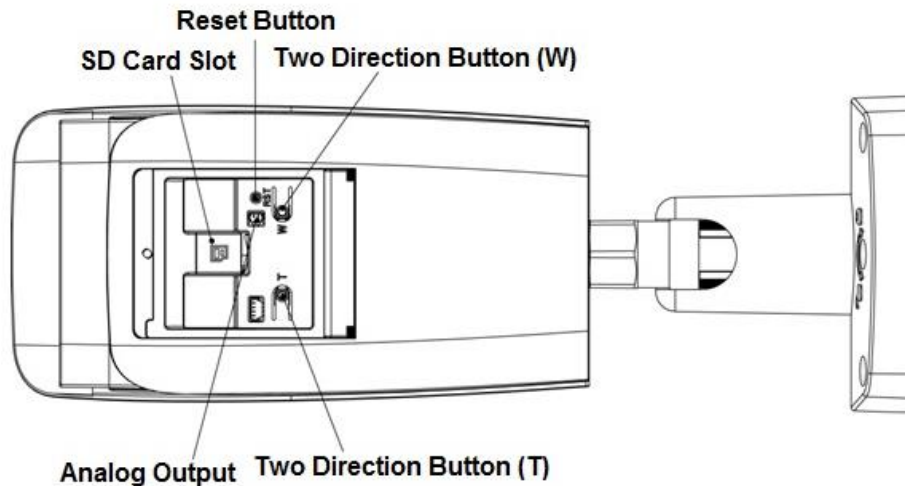

Figure 2-2

Note:

- Motorized vari-focal series devices are equipped with motorized lens by default, which doesn't need manual adjustment; meanwhile the devices with two direction buttons support zoom and focus via the two direction buttons on the panel.
 - You can connect the analog output port to the TV monitor to check image via analog output cable.
 - Press the reset button for 4 to 5 seconds to realize reset function for the device.
3. Install the lower cover back in place, twist back the screw and lock it firmly.

Step 2

Fix the device on the installation surface.

1. Stick the installation position map on the installation surface (wall or ceiling), dig bottom holes of expansion bolt according to the hole sites marked on the installation position map.
2. Open the accessories bag, take out expansion bolt and insert it into the hole you just dug, lock it firmly.
3. Open the accessories bag, take out installation screws. Align the screw hole of the device bottom with the mounting hole sites, and then put the mounting screws into the screw holes and lock them firmly.

The device sun shield can be moved back and forth, it needs to tighten the fixing screw on the sun shield after fixing the device.

Step 3

Plug the external cables of the device properly according to the use requirements.

- Connect the corresponding power, audio cable and alarm input output terminal of the device cable according to the requirement, and then use insulated rubber tape to twine the connection location to make it waterproof.
- Connect the network cable to the corresponding network port of the device cable according to the step 4 of installing waterproof connector for network port.

Step 4

Install waterproof connector for network port (Optional), which is shown in Figure 2-3.

Note

It needs to implement the step when the device is equipped with waterproof connector and it is used outdoors.

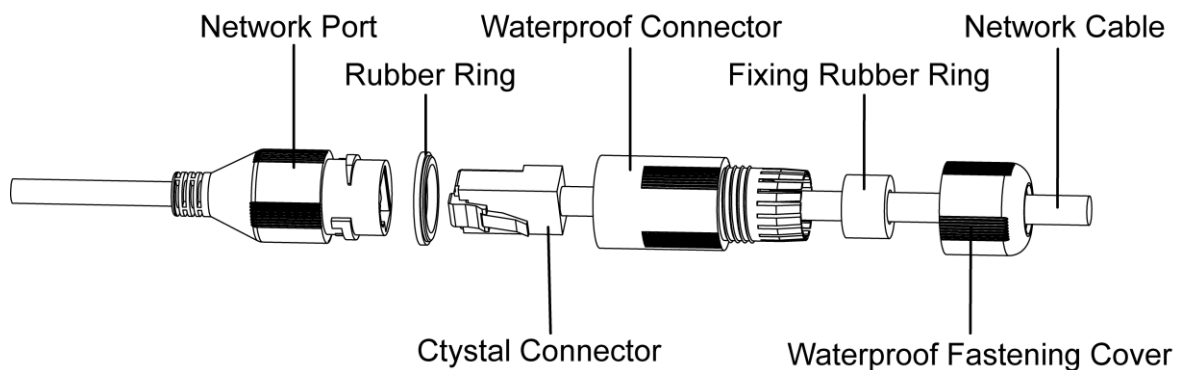

Figure 2-3

1. Keep the convex groove outward and install the rubber ring into the network port, keep the smaller hole of the rubber ring outward and install the fixing rubber ring into the main body of the waterproof connector.
2. Pull the network cable without crystal head through main body of waterproof connector, fixing rubber ring and waterproof locking cover, make the crystal head of network cable, and then insert it into the network cable.
3. Put the main body of waterproof connector on the network port and rotate it clockwise to lock the network port and waterproof connector firmly.
4. Put the waterproof locking cover on the main body of waterproof connector and rotate it clockwise to lock the waterproof connector and waterproof locking cover firmly.

Step 5

Adjust the monitoring direction of the device.

Note

- The location of the adjusting screw may be different due to different models, please refer to the actual product for more details.
- Please be sure to loosen the adjusting screw when adjusting the device position and angle, tighten the adjusting screw after adjustment.
- The continuous rotation toward the same direction for the camera body has to be within 3 circles.
- The lower cover can't be opened for a long time, besides; it can't be opened in the humid environment in case water mist and fog problem may happen to the device.

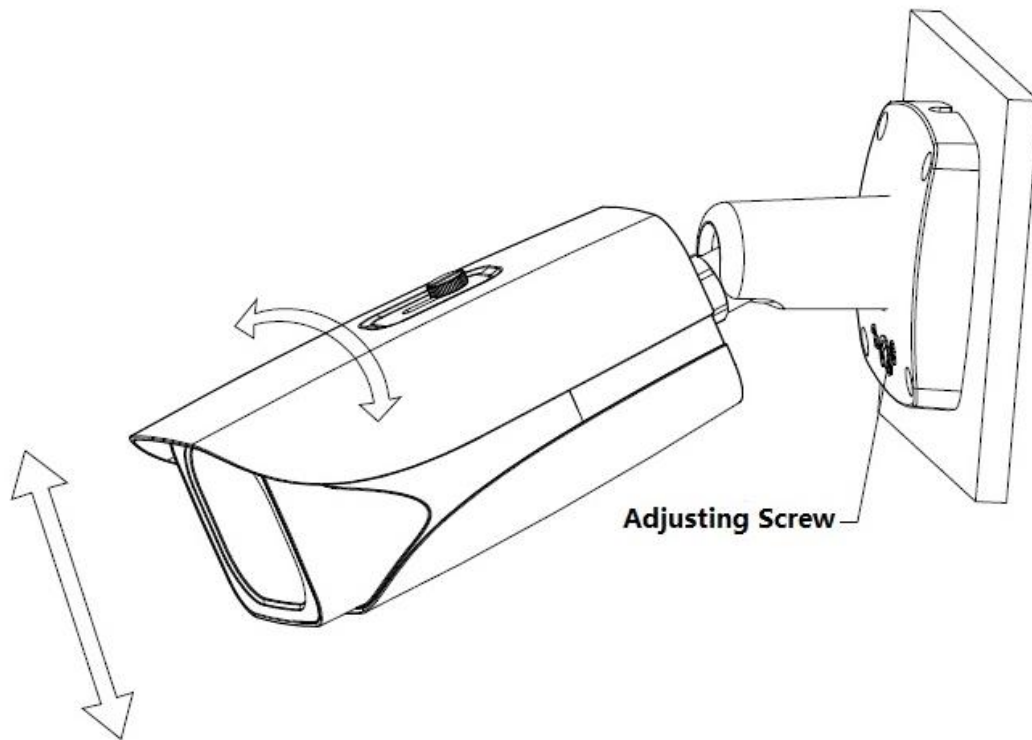

Figure 2-4

1. Use screwdriver to loosen adjusting screw.
2. Adjust the device in all possible directions, and set its monitoring direction according to use requirement.
3. Use screwdriver to tighten the adjusting screws.

3 Network Configuration

The IP address of all the cameras is the same when leaving factory (default IP 192.168.1.108). To make the camera access to the network smoothly, please plan the available IP segment reasonably according to the actual network environment.

3.1 Modify IP Address

The cameras which are accessed via wired network can acquire and modify the IP address through "Quick Configuration Tool". This section introduces the approach of modifying IP address via "Quick Configuration Tool". You can also modify the IP address in the network parameters of the WEB interface. Please refer to the document *WEB Operation Manual* in the disk for more details.

To modify IP address, do the following:

Step 1

Double-click "ConfigTool.exe" to open the "Quick Configuration Tool".

Step 2

Click  to enter the interface where you can modify IP address, and then click **Search setting**.

The system pops up the **Setting** dialog box, see Figure 3-1.

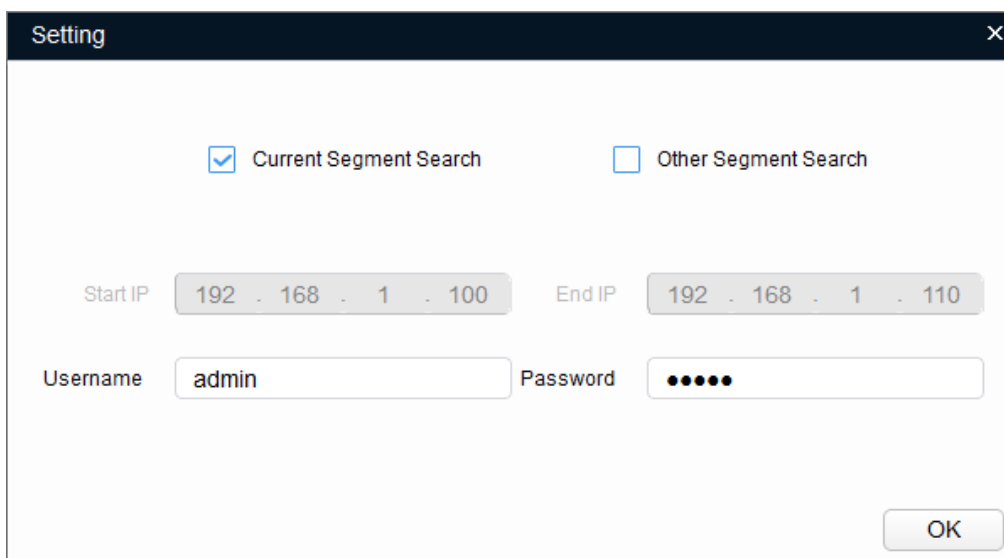

The image shows a "Setting" dialog box with a title bar containing "Setting" and a close button (X). The dialog contains two checkboxes: "Current Segment Search" (checked) and "Other Segment Search" (unchecked). Below these are two IP address input fields: "Start IP" with the value "192 . 168 . 1 . 100" and "End IP" with the value "192 . 168 . 1 . 110". There are also "Username" and "Password" fields. The "Username" field contains "admin" and the "Password" field contains six dots. An "OK" button is located at the bottom right of the dialog.

Figure 3-1

Step 3

Set the device network segment, login user name and password, and then click **OK**. The system will display the searched devices after searching completes.

Note

The default username and password is **admin** and **admin** respectively.

Step 4

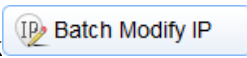
Select the devices which IP addresses need to be modified, and then click .

The system will pop up the **Modify IP Address** dialog box, see Figure 3-2.

Modify IP Address

Mode Static DHCP

Start IP 192 . 168 . 8 . 2 Same IP

Subnet Mask 255 . 255 . 0 . 0

Gateway 192 . 168 . 8 . 1

Selected number of devices: 2 OK

Figure 3-2

Step 5

Set the mode as **Static**, and input the planned **Start IP**, **Subnet Mask** and **Gateway**.

Note

Set the mode as **DHCP** when there is DHCP server in the network, the device will automatically acquire IP address from the DHCP server.

Step 6

Click **OK** to finish modification.

3.2 Login WEB Interface

Note

Different devices might have different WEB interfaces, the figures in this document are just for reference, please refer to the document *WEB Operation Manual* in the disk and the actual interface for more details.

To login WEB interface, do the following:

Step 1

Open IE browser and input the modified camera IP address in the address bar, and then press **Enter** key. The login interface shows, see Figure 3-3.



Figure 3-3

Step 2

Input username and password, click **Login**. The system will pop out WEB main interface.

Note

The default username and password is **admin** and **admin** respectively, please modify the administrator password as soon as possible after you successfully logged in.

Step 3

Click **Here to Download Plug-in**, and then install controls according to the system prompt. See Figure 3-4 or the WEB main interface.

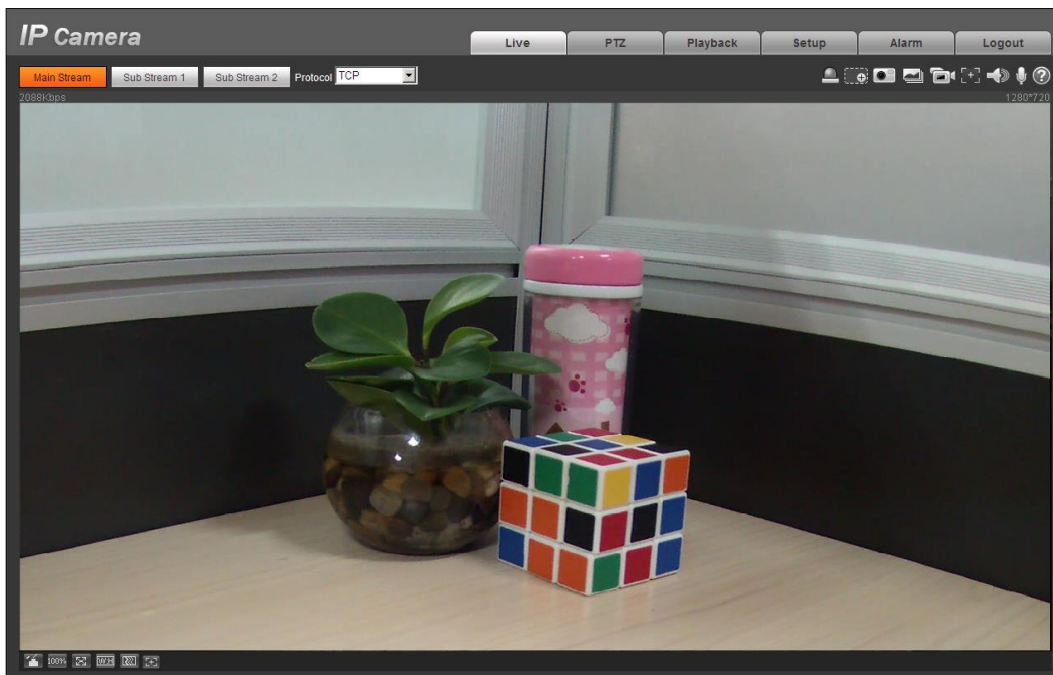

Figure 3-4

Note:

- **This quick start guide is for reference only. Slight difference may be found in user interface.**
- **All the designs and software here are subject to change without prior written notice.**
- **If there is any uncertainty or controversy, please refer to the final explanation of us.**
- **Please visit our website or contact your local service engineer for more information.**