

ICR-300H4-M

2MP Starlight HD-AVS IR Eyeball Camera



- Starlight, 120dB true WDR, 3DNR
- Max. 30fps@1080P
- HD/SD output switchable
- Audio in interface, built-in mic
- 2.7-13.5mm motorized lens
- Max. IR length 50m, Smart IR
- IP67, DC12V±30%

System Overview

Experience 1080P full HD video and the simplicity of reusing existing coaxial infrastructure with HD-AVS. The Starlight HD-AVS camera with 120dB true WDR presents a high quality image with rich details even in extreme low-light conditions. It offers various motorized/fixed lens models with a multi-language OSD and HD/SD switchable output. Its superior image performance and starlight feature makes the camera an ideal choice for mid to large-size businesses and projects where both highly reliable surveillance and construction flexibility are needed.

Functions

4 Signals over 1 Coaxial Cable

HD-AVS technology supports 4 signals to be transmitted over 1 coaxial cable simultaneously, i.e. video, audio*, data and power. Dual-way data transmission allows the HD-AVS camera to interact with the HCVR, such as sending control signal or triggering alarm. Moreover, HD-AVS technology supports PoC for construction flexibility.

*Audio input is available for some models of HD-AVS cameras.

Long Distance Transmission

HD-AVS technology guarantees long-distance and real-time transmission without any loss. It supports up to 800m for 1080P Full HD video via coaxial cable, and up to 300m via UTP cable.

Simplicity

HD-AVS technology inherits the born feature of simplicity from traditional analog surveillance system, making itself a best choice for investment protection. HD-AVS system can seamlessly upgrade the traditional analog system without replacing existing coaxial cabling. The plug and play approach enables full HD video surveillance without the hassle of configuring a network.

Starlight

With the adoption of large sized high performance sensor, the camera is able to provide incomparable performance even under extreme low light environment. The starlight feature allows more details to be captured and accurate color to be recognized at night or in scenes with limited illumination.

Broadcast-quality Audio

Audio information is used as supplementary evidence in video surveillance applications. The HD-AVS camera supports audio signal transmission over coaxial cable. In addition, it adopts unique audio processing and transmission technology that best restores source audio and eliminates noise, guaranteeing the quality and effectiveness of collected audio information.

Multiple-formats

The camera supports multiple video formats including HD-AVS, CVBS, and other two common HD analog formats in the market. A DIP switch located on the cable allows you to quickly toggle formats, further simplifying installation and debugging. This feature makes the camera compatible with not only XVRs, but also most existing HD/SD DVRs.

Wide Dynamic Range

Embedded with industry leading wide dynamic range (WDR) technology, vivid pictures are achieved even in the most intense contrast lighting conditions. True WDR (120dB) optimizes both the bright and dark areas of a scene at the same time to provide usable video.

Advanced 3DNR

3DNR is noise reduction technology that detects and eliminates random noises by comparing two sequential frames. Advanced 3DNR technology allows remarkable noise reduction with little impact to sharpness, especially under limited lighting condition. Besides, the advanced 3DNR effectively decreases the band width and saves the storage space.

Protection

The camera's outstanding reliability is unsurpassed due to its rugged design. The camera is protected against water and dust with IP67 ranking, making it suitable for indoor or outdoor environments.

Technical Specification

Camera

| | |
|--------------------------|---|
| Image Sensor | 1/2.8" CMOS |
| Effective Pixels | 1920(H)×1080(V), 2MP |
| Scanning System | Progressive |
| Electronic Shutter Speed | PAL: 1/4s~1/100,000s NTSC: 1/3s~1/100,000s |
| Minimum Illumination | 0.004Lux/F1.6, 30IRE, 0Lux IR on |
| S/N Ratio | More than 65dB |
| IR Distance | Up to 60m (197ft) |
| IR On/Off Control | Auto / Manual |
| IR LEDs | 2 |

Lens

| | | | | | |
|----------------------|-----------------------------|-------------|------------|------------|-----------|
| Lens Type | Motorized lens / Fixed iris | | | | |
| Mount Type | Board-in | | | | |
| Focal Length | 2.7-13.5mm | | | | |
| Max. Aperture | F1.6 | | | | |
| Angle of View | H: 108.7°~28.7° | | | | |
| Focus Control | Auto / Manual | | | | |
| Close Focus Distance | 200mm 7.87" | | | | |
| DORI Distance | Lens | Detect | Observe | Recognize | Identify |
| | Wide | 44m(144ft) | 18m(59ft) | 9m(30ft) | 4m(13ft) |
| | Tele | 153m(502ft) | 61m(200ft) | 31m(102ft) | 15m(49ft) |

Pan/Tilt/Rotation

| | |
|-------------------------|---|
| Pan/Tilt/Rotation Range | Pan: 0° ~ 360° Tilt: 0° ~ 78° Rotation: 0° ~ 360° |
|-------------------------|---|

Video

| | |
|-----------------|---|
| Resolution | 1080P (1920×1080) |
| Frame Rate | 25/30fps@1080P, 25/30/50/60fps@720P |
| Video Output | 1-channel BNC high definition video output / CVBS video output (DIP switch) |
| Day/Night | Auto (ICR) / Manual |
| OSD Menu | Multi-language |
| BLC Mode | BLC / HLC / WDR (120dB) |
| WDR | 120dB |
| Gain Control | AGC |
| Noise Reduction | 2D/3D |
| White Balance | Auto / Manual |
| Smart IR | Auto / Manual |

Certifications

| | |
|----------------|---|
| Certifications | CE (EN55032, EN55024, EN50130-4) FCC (CFR 47 FCC Part 15 subpartB, ANSI C63.4-2014) UL (UL60950-1+CAN/CSA C22.2 No.60950-1) |
|----------------|---|

Interface

| | |
|-----------------|---|
| Video Interface | 1-channel BNC high definition video output / CVBS video output (DIP switch) |
| Audio Interface | 1ch in & Built-in Mic |
| RS485 | N/A |
| Alarm | N/A |

Electrical

| | |
|-------------------|---------------------------|
| Power Supply | 12V DC ±30% |
| Power Consumption | Max. 5.4W (12V DC, IR on) |

Environmental

| | |
|--|--|
| Operating Conditions | -30°C ~ +60°C (-22°F ~ +140°F) / Less than 95% RH *Start up should be done at above -30°C (-22°F) |
| Storage Conditions | -30°C ~ +60°C (-22°F ~ +140°F) / Less than 95% RH |
| Ingress Protection & Vandal Resistance | IP67 |

Construction

| | |
|--------------|---------------------------|
| Casing | Aluminium |
| Dimensions | Φ122mm×107mm (Φ4.8"×4.2") |
| Net Weight | 0.59kg (1.30lb) |
| Gross Weight | 0.69kg (1.52lb) |

Mounting

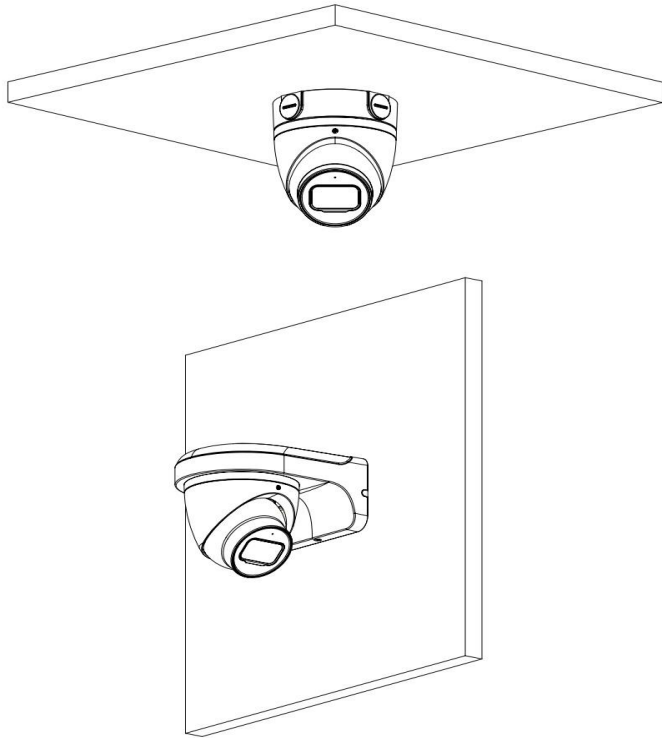

Dimensions (mm/in)

